

Vibration motors

HV 6 GL

Instructions of operation
and
List of spares



Important remark concerning the personal safety of operators



These instructions must be understood by each operator, who is in charge of the assembly, putting into operation, maintenance and repair work of vibration motors. The same applies also to additional modified equipment.

Our vibration motors have been manufactured in according with the latest art. In case of use as provided, they are sure to operate.

Unauthorized changes with the motors and specific execution for the client, are excluded from the manufactures' guarantee for resulting damage. It is an

implied feature of vibration motors that they generate destructive forces. In case of improper use, these destructivforces are apt to cause danger, e.g. the motor or components thereof can drop uncontrolled after getting loose from the fastening means. As a precaution, safety measures must be adopted.

When performing maintenance or repair work, the vibration motor must be cut from the power system. Putting vibration motors into operation without protective cover is forbidden, because risk of accident may result.

Instructions for mounting vibration motors

General

Vibration motors must be mounted only on equipment with plane surfaces, which are resistant to bending. These surfaces must not be tensiond.

Only screws of grade 8.8 and nuts of grade 6 must be used. The screws must be secured from slackening, e. g. by spring washers or the like.

Posterior tightening of screws and nuts

After the first two hours of operation the screws or nuts must be checked for tight seating. Subsequent inspections shall be performed once daily. In case of necessity the screws or nuts must be retightened.

The minnum torques are for: M10 = 55 Nm
M12 = 90 Nm



If the screws have slackened, danger of breakage for the feet of the feet of the vibrator is impending.

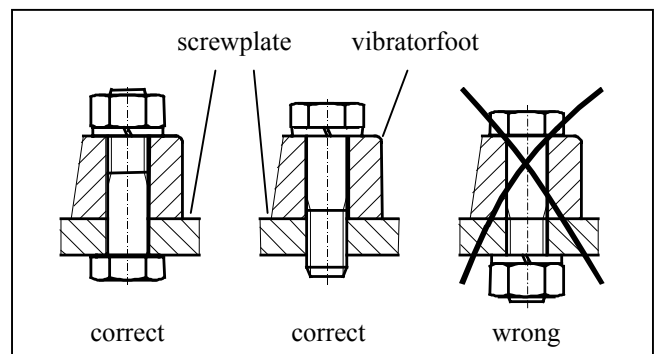

Instructions for establishing the power conection

Allgemein

The power connection must be established only by an electrician. The voltage and periodicitmust be that, which is indicated on the machine plate. The vibration motor must

be connected only to DC. Systems of 12 Vs or 24 Vs which

is in agreement with the VDE regulations.



To secure the motor from overload, it must be fused with 20 A or 16 A slow-action fuses respectively

The power connection

The power connection must be established only by a flexible cable. We recommend to use the following cable type: ÖLFLEX 540 P 2,5²
Plastic cables are not suitable.

1. Remove the cable jacket over a length of 60 mm
2. Provide the ends of the strands with terminals or compression cable sockets. Never fasten the terminals or sockets by soldering, as in default of this the strands

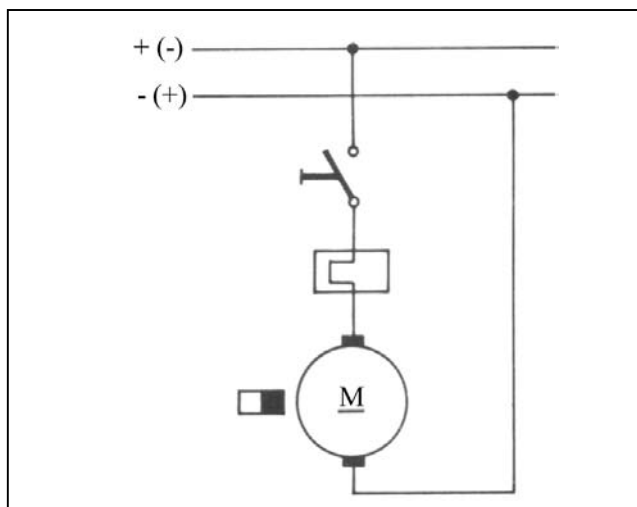

tend to break behind the soldered spots in case of vibration.

3. Introduce the cable into the the terminal box and establish the connection as shown in the diagram.
4. When tightening the cap screw of the screw joint, it must be observed that the cable jacket is still fully seized by the seal. If this is not observed, the cable is not firmly clamped, not relieved from traction, and not waterproof.
5. Close again carefully the terminal box with seal and screws.
6. The power cable must be fastened firmly shortly behind the cable gland. This first fastening of the cable and the motor should by no means be movable against each other. The cable has to be installed in such a way that it does not start vibrating itself and that it is not subject to any tractional forces.
7. When putting the vibration motor into operation the power input must be examined. Should this be larger than the data on the mashine plate, the trouble can be remedied by reducing the centrifugal force.
8. Now and again it must be checked that there are no spots which are subject to friction.

Admitted operating temerature

Outside on the housing not higher than 80°C.

This limit may be surpassed by too high a power input, if the speed which is indicated on the mashine plate is not reached, with the result that the winding may burn out. The

reason may be too high a centrifugal force for the case which is existing or a construction of insufficient resistance to bending. The trouble can be set by reducing the centrifugal force or by using a motor which has a stronger electric drive.

Setting the centrifugal force

Provide that no different centrifugal force had been indicated in the order sheet, the motor has been set for the full centrifugal force. In order to be able to change the centrifugal force both protective covers must be taken of. Once the protective covers are taken off, the centrifugal force may be changed as desired. But it must be observed that the adjustmentis the same on both sides.

This is achieved by removing the screws or nuts from the armature on both sides and by transposing the flywheels by 180°. With this the centrifugal force is reduced by twice the value of the transposed flywheels. But in the case, the removed flywheels must be replaced by spacers.

One flywheel on each side generates the centrifugal forces of 25 daN (3000 min⁻¹).

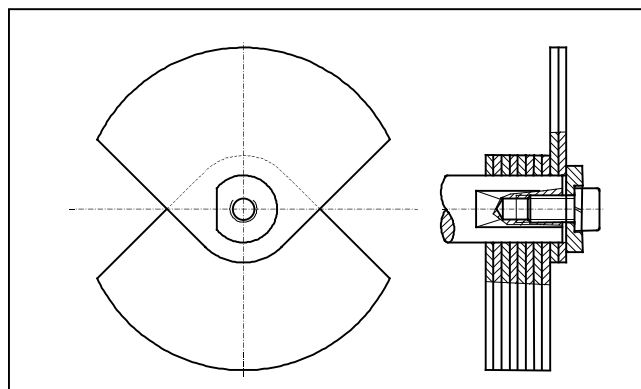

After the adjustment, loosened screws must be tightened again and removed protective

covers must be mounted again. If this is not

observed, risk of accidents is impending.

Maintenance

Motors surfaces must be kept free from accumulations of dirt in order to make sure sufficient cooling. Now and again, the connection cable must be checked for abrasions. After the first two hours of operation the lock screws must be retightened. Subsequent inspections for tight seating of the screws shall be performed once a day. The bearing 's of our motors need no maintenance in normal cases. These bearings have a grease filling for life.

In case of wear of the bearing, the motors shall be taken out of service and the special bearings shall be replaced.

We recommend to send these motors to the manufacturers in order to have these repaired.

Only when doing so you may be sure to get motors repaired properly.

If you proceed to disassemble the motors yourselves or to replace bearings, the workplace must be kept clean. No dirt particles must be allowed to get into the interior of the

motors. Never use cleaning wool, but non-fully cleaning cloths for cleaning motor components.



Never make the motors run without flywheels, because in such cases the bearings could be destroyed!

Maintenance of the carbon brushes

After every 250 hours of operation the carbon brushes should be checked for wear. Remove the protective cover. Push back the clamping rocker of the carbon brush holder and carefully take out the brushes out of the holder with a pair of pliers. Carbon brushes of less than 8 mm length should be replaced. The wires of the brushes are fitted with cable terminals and connected to the carbon brush holder. Make sure that the brush cables cannot get into contact with the bearing cover during operation. Deposited carbon dust can be removed with compressed air of not more than 15 psi.

Spares

When placing orders for spares, please refer to the list of spares.

Further informations is given in the drawings of spares. WÜRGES take over guarantee only for the use of their original spares.

We point out to the fact that spares, which are not delivered by WÜRGES have not been tested by WÜRGES. Using

spares from other manufacturers can impare predetermined qualities which are inherent in the construction and thereby influence negatively the active or passive safety. WÜRGES reject any claim whatsoever, resulting from the use of spares from other manufacturers.

Please keep in mind that many cases, own specifications exist for components of WÜRGES and other manufacturers and that WÜRGES deliver always spares according to the latest art.



When placing orders for spares, never forget to mention the required number of pieces, the type or number.

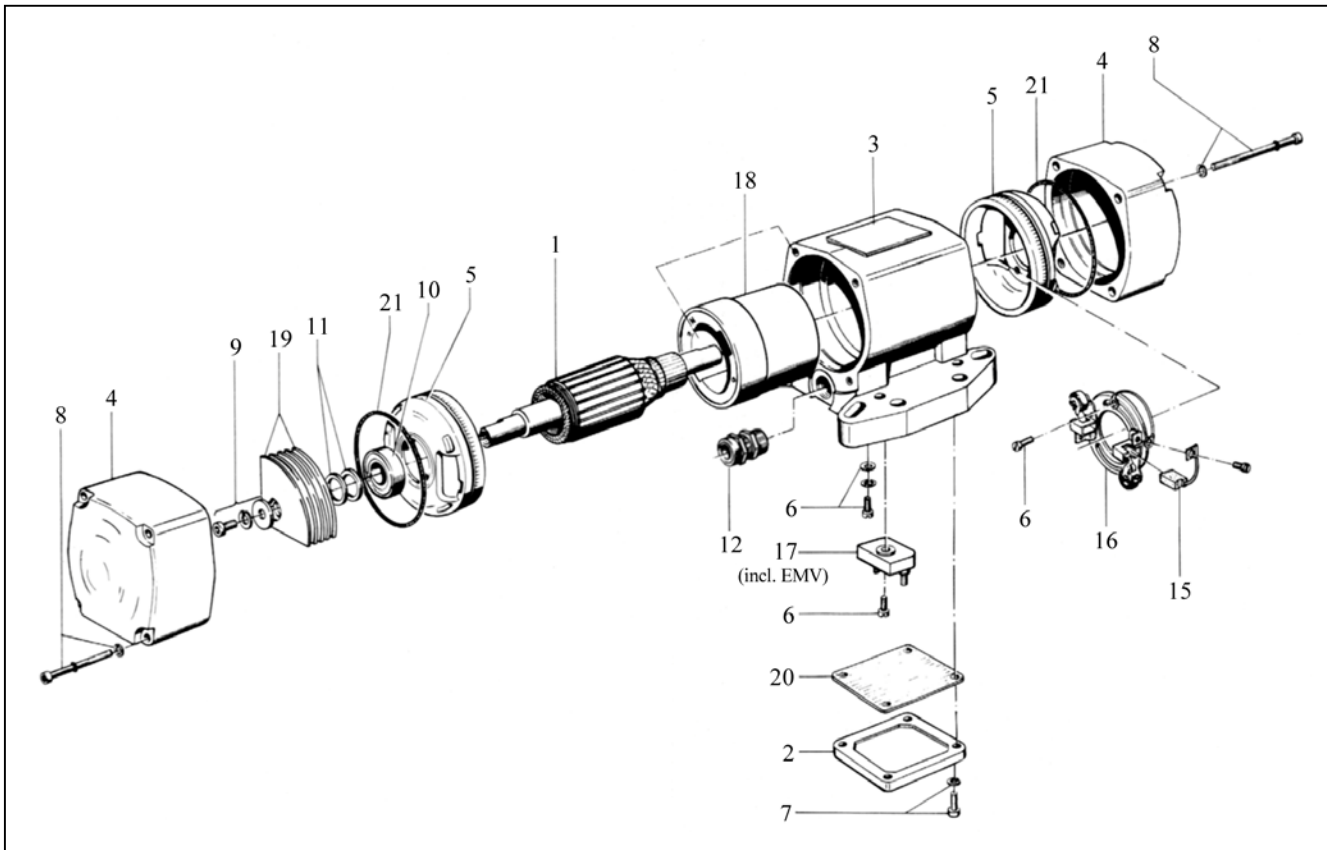

Fig. No.	Order No.	Pieces
1	45801	1
1	45901	1
2	00401	1
3	01401	1
4	01731	2
5	02511	2
6	21101	5

(12V)
(24V)

Fig. No.	Order No.	Pieces
7	21301	4
8	21801	8
9	22551	2
10	24101	2
11	27001	8
12	29491	1
15	50301	2

Fig. No.	Order No.	Pieces
16	50711	1
17	50801	1
18	60011	1
19	75311	10
20	75801	1
21	75931	2

WÜRGES · Vibrationstechnik GmbH
Daimlerstraße 9
D-86356 Neusäß/Augsburg

telephone: 0049/(0)821/463081
telefax: 0049/(0)821/463084
e-Mail: info@wuerges.de
Internet: <http://www.wuerges.de>

