

Installation and Operating Instructions

Electric Vibrators HV/VFL/HF Series



Translation of the Original Instruction Manual



Würges Vibrationstechnik GmbH

Daimlerstraße 9

D-86356 Neusäß

Telephone +49 821 999824-00

Telefax +49 821 999824-10

E-Mail info@wuerges.de

Web www.wuerges.de

Contents

1. General Information	Page 3
2. Symbols Used	Page 4
3. Safety	Page 5
3.1. Intended use	
3.2. Skilled personnel qualifications	
3.3. General safety instructions	
4. Technical Data	Page 7
4.1. Type designation	
4.2. Nameplates	
4.3. Design and function	
5. Transport and Storage	Page 10
6. Installation and Startup	Page 11
6.1. Assembly/Installation	
6.2. Electrical connection/Cable connection	
7. Centrifugal Force Adjustment	Page 15
8. Servicing and Maintenance	Page 18
8.1. Bearing data and re-lubrication	
9. Spare Parts	Page 22
10. Disposal and Recycling	Page 23
11. Warranty	Page 23
12. Appendix	Page 24
• Operating vibrators with capacitors	
• Circuit diagram	
• EU Declaration of Conformity	

1. General Information

Würges electric vibrators are designed and built to state-of-the-art standards and operate safely if used as intended.

The instruction manual must be read and understood by each person in the owner's company who is involved in the installation, startup, maintenance and repair of electric vibrators. The same applies to additional instructions for modified motors.



The instruction manual must be read carefully and in full before using the vibrator motors.

2. Symbols used

The following information and hazard symbols are used in these installation and operating instructions:



ATTENTION

Important information regarding operations or procedures to which particular attention is to be paid.



EXPLOSION HAZARD

Refers to the possibility of fatal, severe or irreversible injuries caused by use of the product in an explosive atmosphere.



HAZARD

Refers to the possibility of fatal, severe or irreversible injuries caused by live parts.



WARNING

Refers to the possibility of fatal, severe or irreversible injuries caused by general hazards.



HOT SURFACE

Refers to the possibility of severe or irreversible injuries caused by touching hot surfaces.



DISCONNECT
MOTOR FROM MAINS

Refers to the fact that the motor must be disconnected from the electricity mains and secured against being switched back on again before any work is carried out on the motor.



ENVIRONMENTALLY
COMPATIBLE DISPOSAL

Refers to the obligation to ensure environmentally compatible disposal.

3. Safety

3.1. Intended use

Electric vibrators are not independently functioning machines. They are used as the drives of vibrating machines such as vibratory conveyor troughs, conveyor pipes, screening machines, grading/sorting machines and knock-out grids.

These machines use vibrations to screen, convey, remove, compact and sort or grade. Any other use is deemed to be not as intended or misuse.

Electric vibrators are designed to generate forces that can be destructive.

The vibrating machine must be designed for the forces generated by the electric vibrators.

The user is responsible for the operation of electric vibrators.

3.2. Skilled personnel qualifications

The installation/assembly, startup and maintenance may only be carried out by authorised and qualified skilled personnel.

3.3. General safety instructions



Electric vibrators generate vibrations. The owner of vibration machines must protect their employees against actual or possible risks to their health and safety caused by the effect of vibrations.



Würges Vibrationstechnik GmbH refuses to accept the responsibility for any damage to property or personal injuries if technical changes have been made to the product or the instructions and regulations in this instruction manual have not been noted and followed.



Live parts can cause severe or fatal injuries.



Electric vibrators must be safely disconnected from the electricity mains before any work is carried out on them. The required procedure is as follows:



1. Switch off vibrator motor
2. Secure against being switched back on again
3. Test for safe disconnection from the power supply



4. Allow the vibrator motor to cool



Do not touch the vibrator motors while they are running or soon after switching them off. The surface temperature of the vibrator motors can reach such high values during operation that there is a risk of burns.



Always use a torque wrench when tightening screws or bolts! Tightening torques see page 11. Attention to maximum tightening torques on page 14 and page 15.



HV/VFL/HF series vibratory motors may not be used in hazardous areas (potentially explosive atmospheres).

4. Technical Data

4.1. Type designation

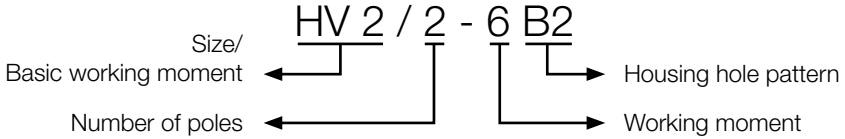

4.2. Nameplates

Size HV 0,1 – HV 1:

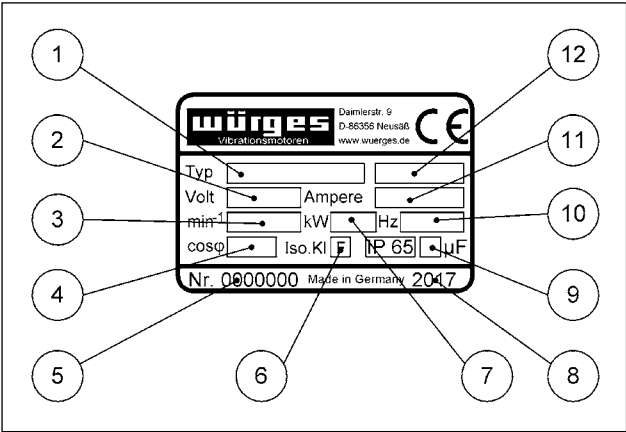

1. Type designation
2. Mains voltage
3. Speed
4. Power factor $\cos \phi$
5. Serial number
6. Thermal insulation class F (155°C)
7. Power input
8. Year built
9. Capacity
10. Mains frequency
11. Nominal current
12. Additional info
e.g. 2MV; PTC thermistor

Size HV 2 and larger:

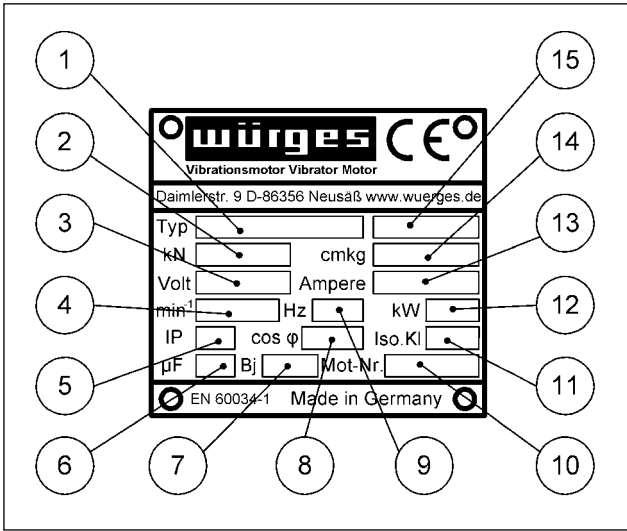

1. Type designation
2. Centrifugal force
3. Mains voltage
4. Speed
5. IP protection
6. Capacity
7. Year built
8. Power factor $\cos \phi$
9. Mains frequency
10. Serial number
11. Thermal insulation class F (155°C)
12. Power input
13. Nominal current
14. Working torque
15. Additional info
e.g. 2MV; PTC thermistor

Please see the data sheet of the motor for additional technical specifications, or our catalogue.

4.3 Design and function (using example of HV 6)

The electrical drive of the HV/VFL series is an asynchronous motor.

The exception is the type HV 2 GL, which has a direct current motor as a drive.

In the sizes HV 1 and HV 2 the stator is cast under vacuum and therefore forms an assembly permanently connected to the housing. On both shaft ends of the motor there are eccentric unbalance plates.

This means a rotating body, whose weight is not distributed rotationally symmetrical or dynamically balanced and therefore causes vibrations. The size of these vibrations can be controlled by weights and counterweights.

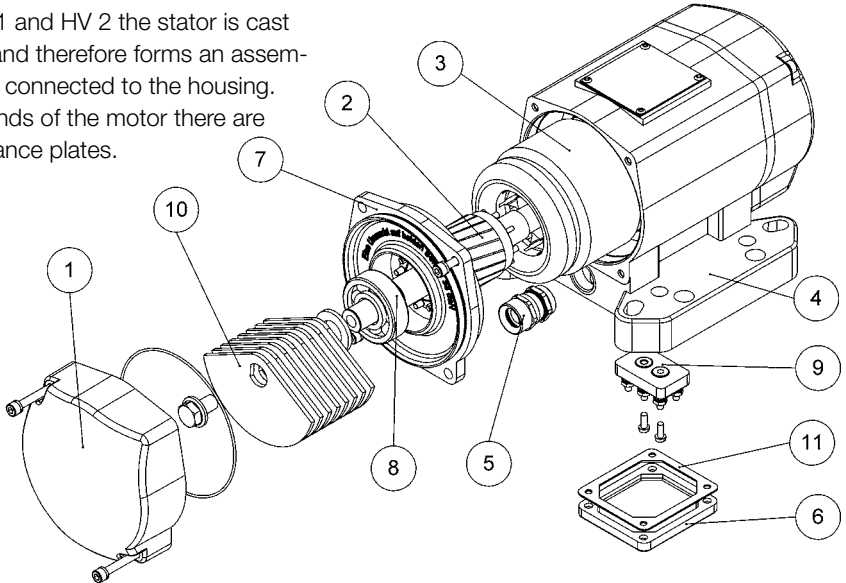

- | | | |
|--------------------|----------------------|----------------------|
| 1 Protective cover | 5 Cable gland | 9 Terminal board |
| 2 Armature | 6 Terminal box cover | 10 Unbalance plates |
| 3 Stator | 7 Bearing end shield | 11 Terminal box seal |
| 4 Housing | 8 Rolling bearing | |

5. Transport and Storage

When they are delivered the motors must be checked for visible transport damage!



If the motor is visibly damaged it must not be started up. The vibratory motor must be examined and if necessary returned to the manufacturer for repair.

Until they are installed the electric vibrators should be stored in enclosed, dry rooms at a max. ambient temperature of 40° C.

Vibrator motors must always be stood on their bases or footings!

Do not stack vibrator motors!



Do not lift up the motor by its installed connection cable.

The eyebolt of the size HV 65 and HV 85 is solely intended for lifting the vibration motor.

Note and follow the local accident prevention regulations.

6. Installation and Startup

6.1. Assembly/Installation

Electric vibrators can be installed in any installation position. Vibrator motors may only be built on to machines with flat, oil, grease and paint-free and flexurally rigid mounting surfaces.

Surface quality

Only bolts in quality class 8.8 > EN ISO 4014 (DIN 931); EN ISO 4017 (DIN 933) and nuts in quality class 6 > 8.8 EN ISO 4032 (DIN 934) may be used.

Tightening torques

M 5	M 8	M 10	M 12	M 16	M 20	M 24	M 27	M 36
8 Nm	30 Nm	55 Nm	90 Nm	150 Nm	280 Nm	450 Nm	1100 Nm	2500 Nm

The bolts must be secured against mechanical loosening by Schnorr washers type VS, Nord-Lock washers or RIPP LOCK® washers.



The fixing bolts must be checked for secure fit after approx. two operating hours and if necessary retightened. Other checks should be carried out daily!



Improper fixing results in the breakage of the feet of the vibratory motor.

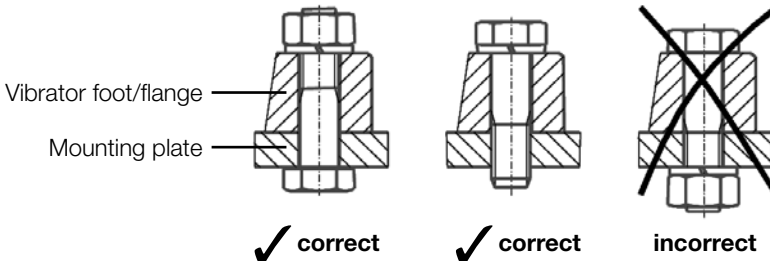

6.2. Electrical connection/cable connection



Electric vibrators must be safely disconnected from the electricity mains before work is carried out on them. The required procedure is as follows:



1. Switch off vibrator motor and secure against being switched back on again
2. Check for safe isolation from supply



3. Allow the motor to cool

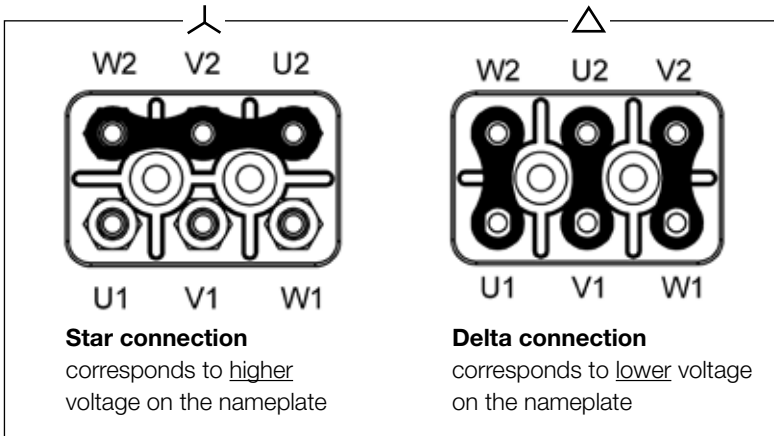

The electrical connection may only be made by a qualified electrician or person who has received the necessary electrical instruction in accordance with EN-60204-1.

The mains voltage may be +- 5%, the mains frequency +- 2% different of the nameplate data. The motor must only be connected to an electricity system that conforms to the VDE provisions.

Each motor must have its own upstream motor protection device as protection against possible overload; the nominal current of this protective device must be set according to the nameplate data.

If two counter-rotating motors are installed, it is necessary to ensure that if one motor fails both motors are switched off (see circuit diagram, page 24).

Speed control

The speed of our three-phase current vibrator motors can be controlled using standard electronic frequency converters.

Please ask about the maximum allowable final speed for each motor type!



Speed reduction until 20 Hz, is easily possible for each type. In case of speed increase above the value given on the nameplate there is a risk of accidents caused by impermissibly high centrifugal forces.

HF-series:

The motors of the HF-series require a frequency converter for power supply.

Cable connection

Only use flexible cables for the connection. We recommend the following cable types:

HV 0.4 to HV 85: H 07 RN-F 4G1.5*
from HV 130: NSHTÖU-J 4G1.5
HV 2 GL: H07 BQ-F 2X2.5
or superior quality*

Plastic cables are unsuitable.

Attach cable lugs or crimp-type cable sockets to the wire ends. Never solder on cable lugs or sockets, as the wire strands near the solder point can break under vibration.

Feed the cables into the terminal box and connect as shown in the circuit diagram above (see page 14). Except HV 0.4 and HV 0.8. These are connected to a European-style terminal strip.

When tightening the cable gland cap nut, ensure that the cable sheath is still fully covered by the seal. If not, the cable will not be securely fixed in place, will not be strain-relieved and will not be watertight.

Re-close the terminal box with seal and screw locking device.

The motor connection cable must be laid fixed for approx. 0.5 m after it exits from the motor. The first fixing point of the cable and the motor must not be able to move against each other during operation. The connection cable must be laid so that natural oscillations are avoided and there is no tensile loading of the cable.

The power input must be checked during the initial startup. If this is larger than the value given on the nameplate this can be remedied by lowering the centrifugal force (see Chapter 7).

The cable must be checked occasionally for chafing and if necessary the cause must be removed.

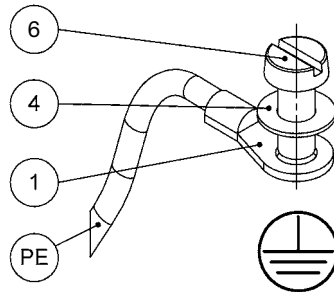
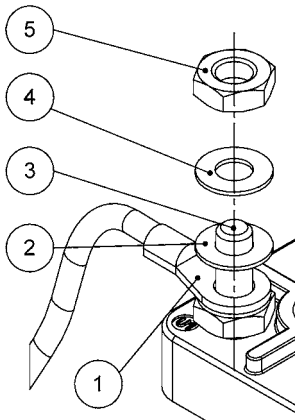

- 1 Cable lug DIN 46237
- 2 Bress shim Messing DIN EN ISO 7090
- 3 Terminal board bolt
- 4 Lock washer DIN 6737/DIN 7980
- 5 Hexagon nut DIN EN ISO 4032
- 6 PE screw M 4 x 8 DIN 84/
M 5 x 10 DIN 7984

Maximum tightening torque terminal board nuts

	HV 1 - HV 30	from HV 40	from HV 180
M 4	M 5	M 6	
1,2 Nm	2,0 Nm	3,0 Nm	

7. Centrifugal Force Setting



Crushing hazard when setting the centrifugal force. Ensure that the armature is fixed. Note and follow the safety instructions on page 6!

If no special centrifugal force setting has been ordered, the motor is set to maximum centrifugal force in the factory.

The centrifugal force has a direct effect on the vibration amplitude of the machine and the power input of the motor.

To adjust the centrifugal force, dismantle both protective covers and undo the unbalance fixing.

HV 0,4 – HV 15, HV 30/2, HV 55/2 and HF

In the case of size HV 0.4 to HV 15, HV 30/2 and HV 55/2 motors the centrifugal force is adjusted in steps by means of push-on unbalance plates.

The centrifugal force is reduced by turning the unbalance plates through 180° at both ends.

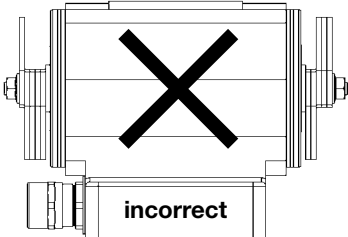
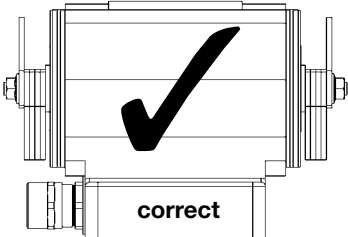

The number of plates changed rotated through 180° must be the same at both ends of the shaft, i.e. they must be symmetrical. (See Fig.) The unbalance plates can also be removed for fine adjustment, they must then be replaced by spacer discs.

Maximum tightening torque of screws at the shaft end

HV 0,4/2	M 5	4 Nm
HV 1	M 5	4 Nm
HV 2	M 8	15 Nm
from HV 6	M 10	20 Nm

Centrifugal force adjustment by means of push-on unbalance plates

The centrifugal force of the motor reduces as follows if the push-on unbalance plates are rotated through 180° or removed:

Speed **2-pole**, 3000 min⁻¹

Motor	Centrifugal force	
	rotated through 180°	removed
HV 0,4/2	50 N	25 N
HV 0,8/2	100 N	50 N
HV 1/2	100 N	50 N
HV 2/2	220 N	110 N
HV 6/2	380 N	170 N
HV 8/2	380 N	170 N
HV 12/2	750 N	375 N
HV 15/2	750 N	375 N
HV 15/2-20	750 N	375 N
HV 15/2-25	1260 N	630 N
HV 30/2	1260 N	630 N
HV 55/2	2100 N	1050 N

Speed **4-pole**, 6000 min⁻¹

Motor	Centrifugal force	
	rotated through 180°	removed
HV 6/4	–	762,5 N
HV 15/4	2400 N	1200,0 N

Speed **4-pole**, 1500 min⁻¹

Motor	Centrifugal force	
	rotated through 180°	removed
HV 1/4	25 N	12,5 N
HV 2/4	55 N	27,5 N
HV 6/4	95 N	47,5 N
HV 12/4-30	187,5 N	93,75 N
HV 12/4-42	350 N	175 N

Speed **6-pole**, 1000 min⁻¹

Motor	Centrifugal force	
	rotated through 180°	removed
HV 6/6	42,5 N	21,25 N
HV 12/6-42	148,67N	74,34 N

Speed **8-pole**, 750 min⁻¹

Motor	Centrifugal force	
	rotated through 180°	removed
HV 6/8	23,75 N	11,88 N
HV 12/8-42	87,33 N	43,67 N

HV 12/4-60 and larger

From size HV 12/4-60 (except HV 30/2 and HV 55/2) the centrifugal force is adjusted by turning the two outer unbalance plates. The percentage centrifugal force can be read off from the scale on the shaft. The adjustment made must be symmetrical.

For tightening torques
of the bolts see page 11

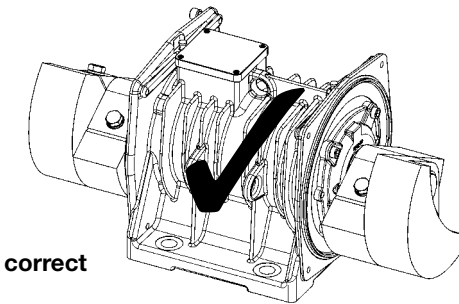
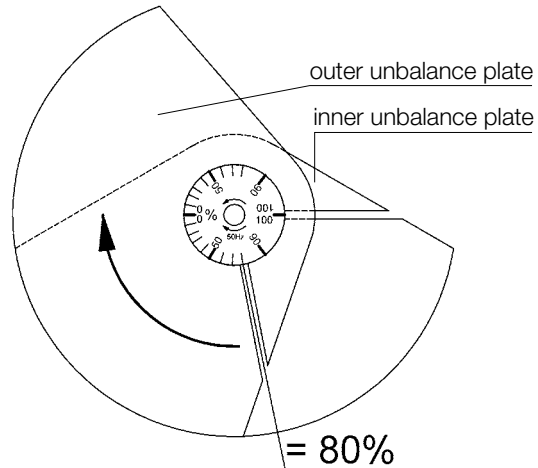

correct

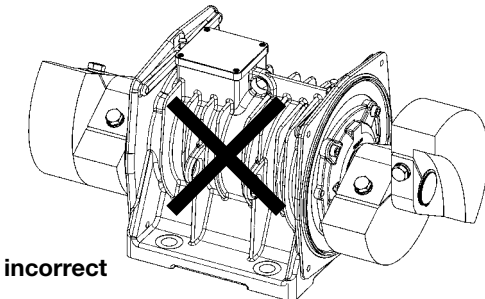

incorrect



After the centrifugal force has been adjusted the loosened bolts and nuts must be retightened and the protective covers must be refitted (tightening torques see page 11). Otherwise there is a risk of accidents! To ensure watertightness ensure that the seals are intact when dismantling and installing the protective covers. Damaged seals must be replaced.



Never operate motors without unbalance plates. This causes damage to the bearings.

8. Servicing and Maintenance



The electric vibrators must always be disconnected from the electricity mains before any work is carried out on it!



1. Switch off vibrator motor
2. Secure against being switched back on again
3. Test for safe disconnection from the power supply



4. Allow the vibratory motor to cool

Maintenance work to be carried out regularly

- The surfaces of the motors must be kept free from dirt deposits in order to ensure adequate cooling.

- Check the connection cable for chafe marks and if applicable remove whatever is causing them.
- Check fixing bolts for secure fit and if necessary retighten.
- Check the seals



The fixing bolts must be retightened after approx. two operating hours (following startup). Other checks should be carried out daily.

8.1. Bearing data and re-lubrication

The bearings of the vibratory motors up to size HV 65 are lubricated for life. It is not normally necessary to carry out maintenance work on the bearings of these motors. We recommend the following lubrication intervals for size HV 85 and larger:

2-pole, 3000 min⁻¹, 50 Hz, 3600 min⁻¹, 60 Hz

Motor	Bearing	Initial lubrication g	Re-lubrication period h		Re-lubrication quantity g		Bearing life h	
			50 Hz	60 Hz	50 Hz	60 Hz	50 Hz	60 Hz
HV 0,1/2	625 ZZ C3						> 100000	> 100000
HV 0,4/2	629 ZZ C3						> 100000	> 100000
HV 0,4/2-1	629 ZZ C3						45000	44000
HV 1/2	6302 ZZ C4						> 100000	> 100000
HV 2/2	6302 ZZ C4						> 100000	> 100000
HV 2/2-2	6302 ZZ C4						77900	73400
HV 2/2-4	6302 ZZ C4						32800	21850
HV 2/2-6	6302 ZZ C4						7500	5500

2-pole, 3000 min⁻¹, 50 Hz, 3600 min⁻¹, 60 Hz

Motor	Bearing	Initial lubrication g	Re-lubrication period h		Re-lubrication quantity g		Bearing life h	
			50 Hz	60 Hz	50 Hz	60 Hz	50 Hz	60 Hz
HV 6/2	6303 ZZ C4						6100	4000
HV 6/2-8	6303 ZZ C4						2300	1700
HV 8/2	NJ 2304 E C4	8.0					> 100000	84000
HV 8/2-11	6303 ZZ C4						1000	750
HV 12/2	6305 ZZ C4						4400	2200
HV 15/2	TMB 305LLB C4						8800	3500
HV 15/2-20	NJ 2305 E C4	8.0					31000	12000
HV 15/2-25	NJ 2305 E C4	8.0					12500	7000
HV 30/2	NJ 2206 E C4	12.0					3500	2300
HV 55/2	NJ 407 M C4	28.0					3600	3400
HV 65/2	NJ 407 M C4	28.0					1600	1300
HV 85/2	NJ 409 V2 C4	40.0	300	150	4	2	1600	1400
HV 85/2-120	NJ 409 V2 C4	40.0	300	150	4	2	500	350
HV 130/2	NJ 2314 E C4	110.0	450	400	8	6	7500	5800

4-pole, 1500 min⁻¹, 50 Hz, 1800 min⁻¹, 60 Hz

HV 1/4	6302 ZZ C4						> 100000	> 100000
HV 1/4-3	6302 ZZ C4						> 100000	> 100000
HV 2/4	6302 ZZ C4						> 100000	> 100000
HV 2/4-2	6302 ZZ C4						> 100000	> 100000
HV 2/4-4	6302 ZZ C4						> 100000	> 100000
HV 2/4-6	6302 ZZ C4						> 100000	> 100000
HV 2/4-9	6302 ZZ C4						> 100000	81000
HV 6/4	6303 ZZ C4						> 100000	> 100000
HV 6/4-11	6303 ZZ C4						73000	52000
HV 6/4-18	6303 ZZ C4						20000	16500
HV 12/4-18	6305 ZZ C4						> 100000	> 100000
HV 12/4-30	6305 ZZ C4						36000	15500
HV 12/4-42	6305 ZZ C4						23000	11650
HV 12/4-60	NJ 2305 E C4	8.0					86500	70200
HV 30/4-75	NJ 2206 E C4	12.0					23500	19900
HV 55/4-120	TMB 6407 ZZ C4						11500	9000
HV 55/4-150	TMB 6407 ZZ C4						9500	7900
HV 65/4-200	TMB 6407 ZZ C4						3400	2800
HV 85/4-400	NJ 409 V2 C4	40.0	600	300	4	2	1700	1500
HV 130/4-500	NJ 2314 E C4	110.0	2000	1800	20	20	16000	13500
HV 180/4-700	NJ 2317 E C4	150.0	2000	1600	32	32	18000	16500

6-pole, 1 000 min⁻¹, 50 Hz, 1 200 min⁻¹, 60 Hz

Motor	Bearing	Initial lubrication g	Re-lubrication period h		Re-lubrication quantity g		Bearing life h	
			50 Hz	60 Hz	50 Hz	60 Hz	50 Hz	60 Hz
HV 6/6	6303 ZZ C4						> 100000	> 100000
HV 6/6-18	6303 ZZ C4						> 100000	> 100000
HV 12/6-42	6305 ZZ C4						> 100000	> 100000
HV 12/6-60	6305 ZZ C4						86500	70000
HV 30/6-75	6305 ZZ C4						33000	28500
HV 55/6-120	TMB 6407 ZZ C4						> 100000	> 100000
HV 55/6-150	TMB 6407 ZZ C4						> 100000	83000
HV 65/6-200	TMB 6407 ZZ C4						37000	31000
HV 65/6-300	TMB 6407 ZZ C4						18300	15000
HV 85/6-400	NJ 409 V2 C4	40.0					32000	12700
HV 85/6-600	NJ 409 V2 C4	40.0					9100	7500
HV 130/6-800	NJ 2314 E C4	110.0	4000	3600	20	20	> 100000	75000
HV 130/6-1000	NJ 2314 E C4	110.0	4000	3600	20	20	41000	35000
HV 130/6-1250	NJ 2314 E C4	110.0	4000	3600	20	20	18500	16720
HV 180/6-1400	NJ 2317 E C4	150.0	3500	3400	32	32	35800	29900
HV 180/6-1600	NJ 2317 E C4	150.0	3500	3400	32	32	25000	21000

8-pole, 750 min⁻¹, 50 Hz, 900 min⁻¹, 60 Hz

HV 6/8	6303 ZZ C4						> 100000	> 100000
HV 6/8-18	6303 ZZ C4						> 100000	> 100000
HV 12/8-42	6305 ZZ C4						> 100000	> 100000
HV 12/8-60	6305 ZZ C4						> 100000	76500
HV 30/8-75	6305 ZZ C4						> 100000	37800
HV 55/8-120	TMB 6407 ZZ C4						> 100000	> 100000
HV 55/8-150	TMB 6407 ZZ C4						> 100000	> 100000
HV 65/8-200	TMB 6407 ZZ C4						> 100000	75000
HV 65/8-300	TMB 6407 ZZ C4						82000	23000
HV 85/8-400	NJ 409 V2 C4	40.0					> 100000	68000
HV 130/8-800	NJ 2314 E C4	110.0	6000	5500	20	20	> 100000	> 100000
HV 130/8-1000	NJ 2314 E C4	110.0	6000	5500	20	20	> 100000	72000
HV 180/8-1400	NJ 2317 E C4	150.0	5500	5000	32	32	> 100000	83000
HV 180/8-1600	NJ 2317 E C4	150.0	5500	5000	32	32	> 100000	58000

DC, 3000 min⁻¹

HV 2 GL	6002 ZZ C4							5800
HV 2 GL Verst.	6002 ZZ C4							1000

HF, 6000 min⁻¹, 200 Hz, 3000 min⁻¹, 200 Hz

Motor	Bearing	Initial lubrication g	Re-lubrication period h		Re-lubrication quantity g		Bearing life h	
			50 Hz	60 Hz	50 Hz	60 Hz	50 Hz	60 Hz
HF 6/4	6303 ZZ C4							1 800
HF 6/8	6303 ZZ C4							3 800
HF 15/4	NJ 2305 EM C4	8.0						5 000

For especially high loads, various motors, as special designs, are equipped with lubrication nipples DIN 71412 for regreasing:

Motor	Bearing	Initial lubrication g	Re-lubrication period h		Re-lubrication quantity g		Bearing life h	
			50 Hz	60 Hz	50 Hz	60 Hz	50 Hz	60 Hz
HV 15/2 S*	NJ 2305 E C4	8.0	1 000	500	3.0	1.5	> 100 000	> 100 000
HV 30/2 S*	NJ 2206 E C4	12.0	800	400	4.0	2.0	3 500	2 300
HV 55/2 S*	NJ 407 M C4	28.0	500	250	5.0	2.5	3 600	3 500

We recommend the following long-life grease:
Mobile UNIREX N3.

In case of signs of bearings wear the motors should be switched off immediately and the special bearings replaced.

We recommend that you send the motors to the manufacturer for repair (including if other types of damage occur). This is the only way to ensure proper repair.

Allowable operating temperature

The temperature on the outside of the housing must not exceed 80°C.

This limit can be exceeded if the power input is too high, if the speed given on the nameplate is not reached. This can cause the winding to burn out.

A possible cause is that the centrifugal force is too high for the specific application or the design is insufficiently flexurally rigid.

One remedy is to reset the centrifugal force or to use a motor with stronger electrical drive.

9. Spare Parts

To order spare parts, please refer to the drawing on page 9.

Please always give the following information with each order for spare parts:

- Motor type
- Motor number
- Description, item and position number of the part
- Required quantity

We will send you spare part lists on request.

We only provide warranty for the original spare parts supplied by us.

We expressly point out that spare parts and accessories that are not original parts supplied by us have not been tested and approved by us. Installing and/or using such products can therefore cause negative changes to the specified design properties and therefore impair active and/or passive safety.

Würges does not accept any liability whatsoever or provide any warranty for damage caused by the use of non-original spare parts and accessories.

10. Disposal and Recycling

Packaging materials and motor components must be disposed of in an environmentally compatible way.

Steel:

Unbalance plates, armature and rotor, bolts, nuts and bearing, housing (from HV 130 onwards)

Aluminium:

Housing, protective covers, terminal box cover and nameplate

PE:

Seals/gaskets

Copper and synthetic resin:

Winding



**You can return the motors to us for proper disposal!
They must be delivered to us carriage paid.**

11. Warranty

Würges provides warranty for 1 year, beginning with delivery, for all new vibrating motors.

Warranty expires when:

- the motor is connected wrong, or connected with wrong voltage,
- the motor fails because of missing or wrong electric protection,
- there were changes made to the motor,
- the motor was damaged during transport,
- the motor was not installed as shown in chapter 6,
- the motor was connected with wrong cable,
- there is misuse/not intended use,
- the instructions of the manual are not followed.

Operating vibrators with capacitors (3~ 230/400 V 50 Hz)

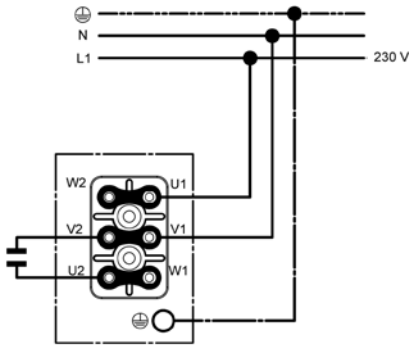

Operating capacitors with 320 V

Three phase vibrator motors with (3~ 230/400 V 50 Hz) to be supplied with 1~ AC 230 V 50 Hz

The motor has to be connected to Δ 230 V. Exception: HV 0,4/2 and HV 0,8/2

Vibrator Motor	Capacitor [μF]	Remarks
HV 0,4/2 230V	2	continuous duty 100 %
HV 0,8/2 o.F. 230V	2	continuous duty 100 %
HV 1/2	7	continuous duty 100 %
HV 2/2	12	intermittent duty max. 40 %
HV 2/2-2	12	intermittent duty max. 40 %
HV 2/2-4	12	intermittent duty max. 40 %
HV 6/2	30	intermittent duty max. 40 %
HV 8/2	30	intermittent duty max. 40 %
HV 8/2-11	25	intermittent duty, for use on silos only
HV 1/4	4	continuous duty 100 %
HV 2/4-4	10	continuous duty 100 %

Operating single phase vibrators with capacitors (1~ 230 V 50 Hz)

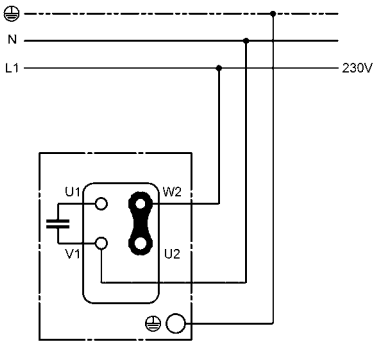

Operating capacitors with 320 V.

Single phase vibrator motors to be supplied with 1~ AC 230 V 50 Hz

For continuous operation

Vibrator Motor	Capacitor [µF]	Remarks
HV 2/2	7	continuous duty 100 %
HV 2/2-2	7	continuous duty 100 %
HV 2/2-4	7	continuous duty 100 %
HV 2/2-6	7	continuous duty 100 %

Circuit Diagram

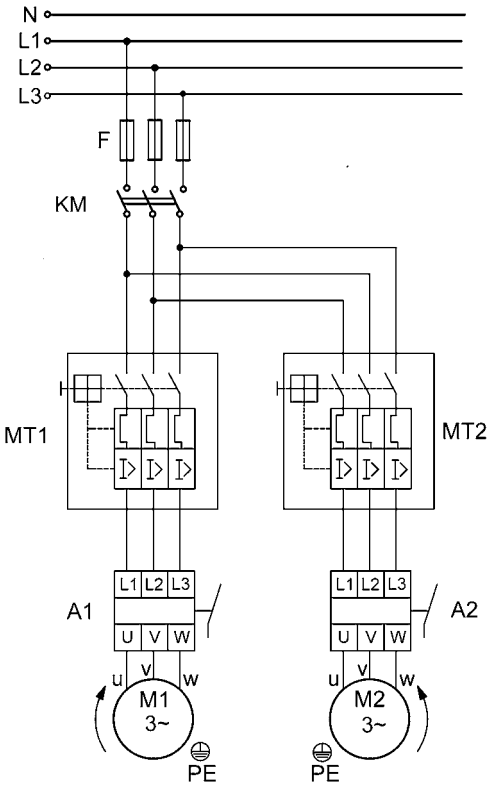

- MT1 Motor protection switch motor 1
- MT2 Motor protection switch motor 2
- A1 Strand break relais motor 1
- A2 Strand break relais motor 2
- KM Main switch
- F Fuse

EU Declaration of Conformity

Hereby declares the manufacturer

Würges Vibrationstechnik GmbH, Daimlerstr. 9, 86356 Neusäß:

The rotary electric vibrator motors of the series

HV / VFL / HF

Are conform to the following European directives:

2014/35/EU (Low Voltage)

2014/30/EU (EMC)

2011/65/EU (RoHS)

The compliance with the provisions of the directives is proved by the following standards:

EN 60034-1 / 2015

EN ISO 12100 / 2011

EN 61000-6-2 / 2011

EN 61000-6-4 / 2011

The manufacturer will electronically transmit the specific documents to national bodies on request.

The designated product is to be seen as a component for installation into a machine or system. Commissioning is prohibited until the conformity of the final product to the directive 2006/42/EC is established.

The safety instructions of the product documentation must be duly observed.

This declaration of conformity is no warranty of the characteristics in the sense of product liability.

Neusäß, 01.06.2017

Würges Vibrationstechnik GmbH



Dipl.-Ing.(FH)

Philipp Würiges

Managing Director

Würges Vibrationstechnik GmbH

Daimlerstraße 9

D-86356 Neusäß

Telephone +49 821 999824-00

Telefax +49 821 999824-10

E-Mail info@wuerges.de

Web www.wuerges.de

© 06/2017