

Vibration motors

HVe 1



II 3G / D

Instructions of operation

and

List of spare parts



Important remarks concerning the personal safety of operators



These instructions must be understood by the person in charge of mounting vibration motors, of putting them into operation as well as of maintenance and repair work.

Our vibration motors are manufactured in accordance with the latest art. If used as intended, they are safe to operate.

Unauthorized modifications to the motors exclude any warranty on the part of the manufacturer for damage that may result.

Vibration motors generate destructive forces due to their design. They can become a source of great danger, if used in a way they are not intended for. They may, for instance, tumble to the ground in an uncontrolled manner, if not mounted properly. Thus it is recommended that suitable safety measures are put in place.

When performing maintenance or repair work, vibration motors must be disconnected from the power supply. Operating vibration motors without weight protective caps is forbidden because of the risk of accidents.

The operator is responsible for the correct, intended use in potentially explosive atmospheres.

The motors of construction size HVe 1 are designed and constructed according to Directive 94/9/EC and belong to machine group II. Their maximum surface temperature T is 120°C .

They comply with the requirements of category 3 for potentially explosive atmospheres of dust zone 22 and gas zone 2. The regulations of the standard EN 50281-1-1-2, regarding, for instance, temperature requirements and dust deposits have to be observed.

Instructions for mounting vibration motors

General remarks

Vibration motors must be mounted only on plane and level surfaces, which are resistant to bending. They must not be wrenched or strained out of line or position.

Only bolts of grade 8.8 and nuts of grade 6 must be used. They must be secured against loosening by means of spring washers or the like.

Subsequent tightening of nuts and bolts

After about two hours of operation the nuts and bolts must be checked whether they are still solidly fixed in place. If necessary, they must be tightened up again. Subsequent inspections should be made on a daily basis.

The minimum torque to be applied on $M8 = 30\text{ Nm}$



If the bolts have loosened, the foot of the vibrator is likely to break and hence, there is the risk of accidents.

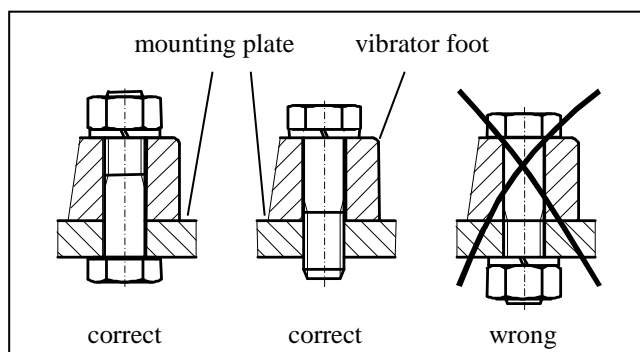

Instructions for establishing the electrical connection



Dangerous Voltage!
Non-compliance can cause death, serious injuries and/or damage to property.

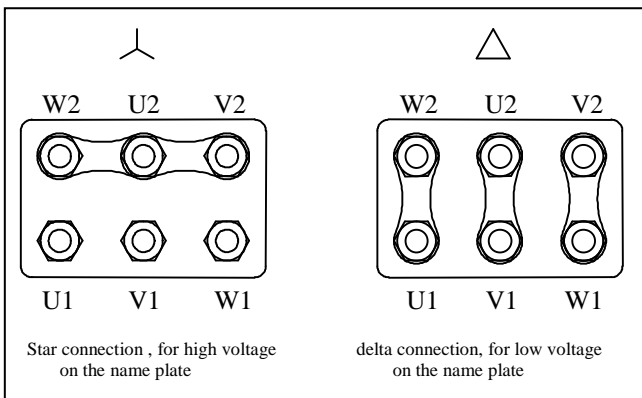

General remarks

The electrical connection must be established only by a skilled electrician. Voltage and frequency must be in accordance with the values specified on the name plate. The motor must be connected only to a power supply which conforms to the respective VDE regulations.

Regulating the speed by means of conventional electronic frequency converters is not admissible.

To guard against overload, every motor must be provided with motor protection, whose nominal current is to be adjusted according to the value specified on the name plate. The installed motor protection has to trip within the time t_E .

Electrical connection

HVe 1 motors have already been equipped with flexible connection cable in the factory. Only the cable type ÖLFLEX FD ROBUST C 4 G 1,5 must be used.

Regarding subsequent installation or repair service, please proceed as follows:

1. Provide the wire ends with crimp loop terminals or loop crimp socket terminals. Never attach them by soldering, or else the wire strands can break during operation next to the solderings.
2. Insert the cable into the terminal box and make the connection as shown in the diagram.
3. When tightening the cap screw of the screw joint, it must be observed that the cable jacket is still fully seized by the seal. If this is not observed, the cable is not firmly clamped, not relieved from traction, and not waterproof.
4. Close again carefully the terminal box with seal and screws.
5. The connection cable must be solidly and firmly fixed to its attachments outside of the motor. The first attachment of the cable and the motor must not be movable against each other during operation. The cable must be so arranged that it is neither induced to resonance vibrations nor exposed to mechanical stress or strain.
6. When putting the vibration motor into operation the power input must be examined. Should this be larger than the data on the nameplate, the trouble can be remedied by reducing the centrifugal force.
7. Now and again it must be checked that there are no spots which are subject to friction.



In case the free end of the cable is going to be connected within an Ex zone, a terminal box has to be used which meets the respective requirements.

Instructions concerning temperature rise during operation

Provision must be made against inadmissible temperature rise due to overload by installing a motor protection device with current-controlled as well as time-controlled actuation. This protective device must not have a higher rating than that of actuation CLASS 5 (10A) and is to be adjusted according to the nominal current of the motor. Thereby it is guaranteed that the motor is also thermally protected. In case of a short circuit (ie. with the rotor being seized up).

The motors can only be used for continuous operation (S1) and only for applications with infrequently occurring run-

ups of the motor, during which there is no substantial temperature rise.

In case of exposure to excessive current, the number of rotations specified on the name plate is probably not being reached. This can lead to the burning of the stator. A possible cause can be a force adjustment which is too high for the application or a construction with insufficient resistance to bending. This can be corrected by reducing the centrifugal force.

Setting the centrifugal force

Provided that no different centrifugal force had been indicated in the order sheet, the motor has been set for the

full centrifugal force. In order to be able to change the centrifugal force both protective caps must be taken off.



Once the protective caps are taken off, the centrifugal force may be changed as desired. But it must be observed that the adjustment is the same on both sides.

This is achieved by removing the screws or nuts from the shaft on both sides and by transposing the flywheels by 180°. With this the centrifugal force is reduced by twice the value of the transposed flywheels. But in this case, the removed flywheels must be replaced by spacers. (Please compare the corresponding list of spares).

One flywheel on each side generates the following centrifugal forces, depending on the type of motor and speed:

$$\begin{aligned} \text{Speed with 2 poles} &= 3000 \text{ min}^{-1} \frac{\text{HVe } 1/2}{\text{HVe } 1/4} = 10 \text{ daN} \\ \text{Speed with 4 poles} &= 1500 \text{ min}^{-1} \frac{\text{HVe } 1/2}{\text{HVe } 1/4} = 2,5 \text{ daN} \end{aligned}$$

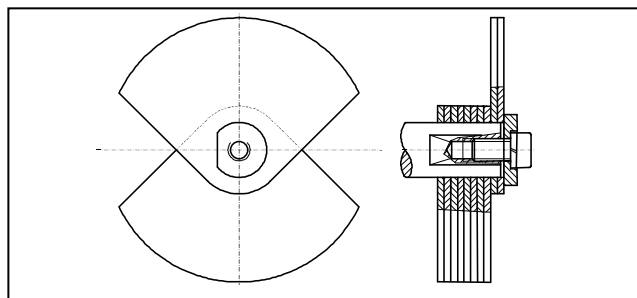

After the adjustment, loosened screws must be tightened again and the protective caps must be mounted again. If this is not observed, risk of accidents is impending.

Maintenance

Motors surfaces must be kept free from accumulation of dirt in order to make sure sufficient cooling. Now and again, the connection cable must be checked for abrasions. After the first two hours of operation the lock screws must be retightened. Subsequent inspections for tight seating of the screws shall be performed once a day. The bearings of our motors need no maintenance in normal cases. These bearings have a grease filling for life. In case of wear of the bearing, the motors shall be taken out of service and the special bearings shall be replaced.

We recommend to send these motors to the manufacturers in

order to have these repaired. Only when doing so you may be sure to get motors repaired properly.

If you proceed to disassemble the motors yourselves or to replace bearings, the workplace must be kept clean. No dirt particles must be allowed to get into the interior of the motors. Never use cleaning wool, but non-fluffy cleaning cloths for cleaning motor components.



Never make the motors run without flywheels, because in such cases the bearings could be destroyed.

Spares

When placing orders for spares, please refer to the list of spares and the drawings of spares.

We take over guarantee only for the use of their original spares. We point out to the fact that spares, which are not delivered by us have not been tested by us. Using spares from other manufacturers can impair predetermined

qualities which are inherent in the construction and thereby influence negatively the active or passive safety. We reject any claim whatsoever, resulting from the use of spares from other manufacturers.

Please keep in mind that many cases, own specifications exist for components of us and other manufacturers and that we deliver always spares according to the latest art.

The name plates are as follows:

würges D-Mot.	
Vibrationsmotoren D-86356 Neusäß	
CE 0035	Ex II 3G / D T=120° year
Type	HVe 1/2 serial number
V 400λ	Hz 50 min ⁻¹ 2600
A 0,17	P ₁ kW 0,09 cos φ 0,8
Wärmkl.F-IP65-S1-EN60034-EN50014/50019 94/9/EC (ATEX) Made in Germany Anschlußkabel: Ölflex FD robust C 4 G 1,5	

würges D-Mot.	
Vibrationsmotoren D-86356 Neusäß	
CE 0035	Ex II 3G / D T=120° year
Type	HVe 1/4 serial number
V 400λ	Hz 50 min ⁻¹ 1250
A 0,15	P ₁ kW 0,06 cos φ 0,58
Wärmkl.F-IP65-S1-EN60034-EN50014/50019 94/9/EC (ATEX) Made in Germany Anschlußkabel: Ölflex FD robust C 4 G 1,5	

Admissible range of voltages:

Voltages in between those specified above are admissible. The respective currents are determined according to the reciprocal relation between voltage and current.

motor	Hz	V
HVe 1/2	50	42 - 750
HVe 1/2	60	42 - 750
HVe 1/4	50	42 - 750
HVe 1/4	60	42 - 750



When placing orders for spares, the type, number of the motor, number of the item and number of pieces required must be mentioned, for item 12 also voltage and periodicity.

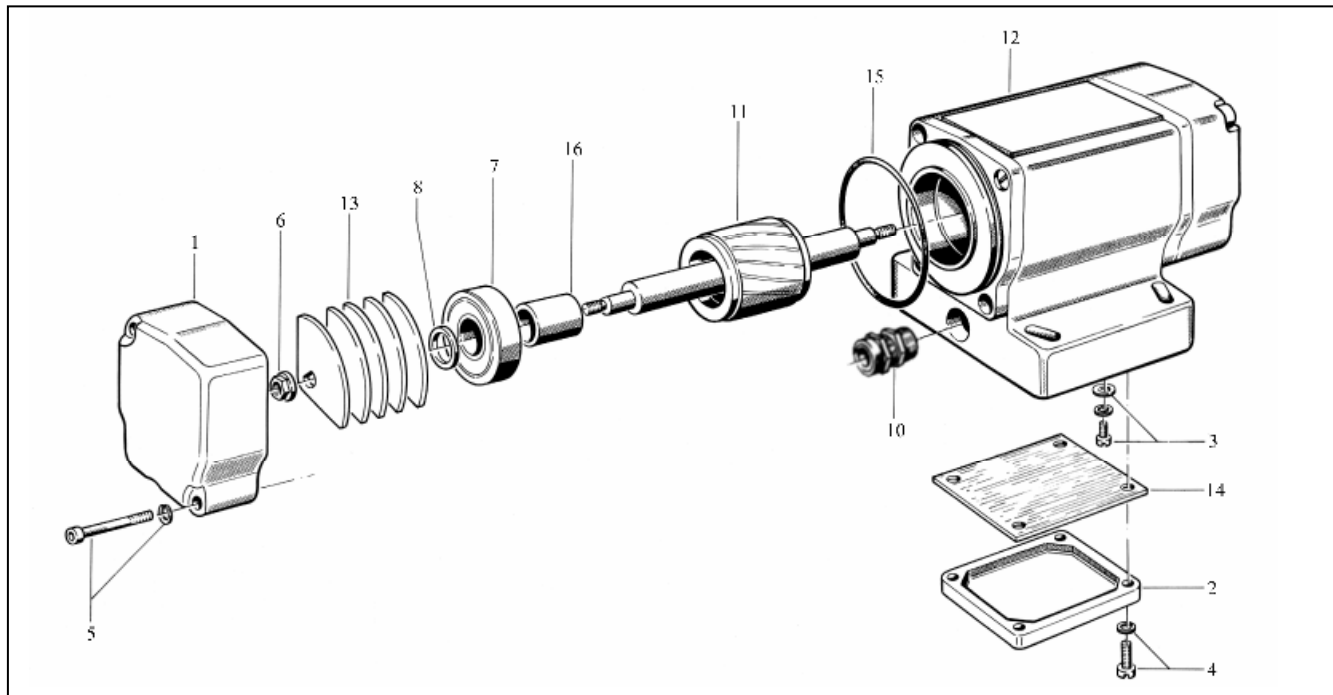

	Fig. No.	Order No.	Pieces
HVe 1/2	1	00301	2
	5	21701	4
	11	45201	1
	12	60601	1
	13	75301	10
HVe 1/4	1	00301	2
	5	21701	4
	11	45201	1
	12	60611	1
	13	75301	10

	Fig. No.	Order No.	Pieces
HVe 1/4-3	1	00351	2
	5	22101	4
	11	45251	1
	12	60641	1
	13	75301	34

cable	63111	2m
-------	-------	----

Fig. No.	Order No.	Pieces
2	00401	1
3	21101	1
4	21301	4
6	23801	2
7	24301	2
8	27001	2
10	29491	1
14	75801	1
15	75901	2
16	76401	2

WÜRGES · Vibrationstechnik GmbH
Daimlerstraße 9
D-86356 Neusäß/Augsburg

telephone: 0049/821/463081
telefax: 0049/821/463084
e-Mail: info@wuerges.de
Internet: <http://www.wuerges.de>



