

Vibrationsmotoren

MR-1

**Instructions of operation
and
List of spares**



Important remark concerning the personal safety of operators



These instructions must be understood by each operator, who is in charge of the assembly, putting into operation, maintenance and repair work of magnetic vibrators. The same applies also to additional modified equipment.

Our magnetic vibrators have been manufactured in according with the latest art. In case of use as provided, they are sure to operate.

Unauthorized changes with the vibrators and specific execution for the client are excluded from the manufactures' guarantee for resulting damage.

Vibration motors generate destructive forces due to their design. They can become a source of great danger, if used in a way they are not intended for. They may, for instance, tumble to the ground in an uncontrolled manner, if not fastened properly. Thus it is recommended that suitable safety measures are put in place.

When performing maintenance or repair work, the vibrator must be cut from the power system. Putting vibrators into operation without protective cover is forbidden, because risk of accident may result.

Instructions for mounting vibrators

General

Magnetic vibrators must be mounted only on equipment with plane surfaces, which are resistant to bending. Neither should the base of the vibrator be allowed to bend.

Only screws of grade 8.8 and nuts of grade 6 must be used. The screws must be secured from slackening, e. g. by spring washers or the like.

Posterior tightening of screws and nuts

After the first two hours of operation the screws or nuts must be checked for tight seating. Subsequent inspections shall be performed once daily. In case of necessity the screws or nuts must be retightened.

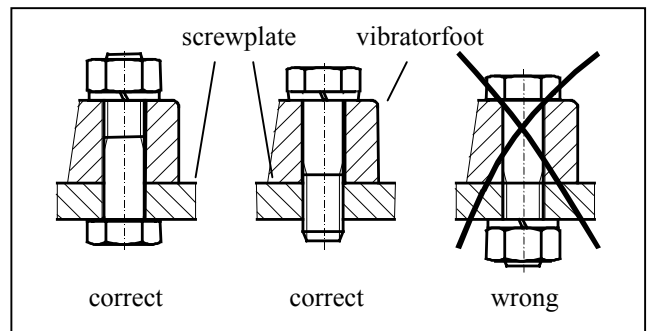

If the screws have slackened, danger of breakage for the feet of the feet of the vibrator is impending.

Torques

The minnum torque is for: M8 = 30Nm

Instructions for establishing the power conection



Dangerous Voltage!
Non-compliance can cause death, serious bodily injury or property damage.

General

The power connection must be established only by an electrician. The voltage and periodicity must be that, which is indicated on the machine plate. The magnetic vibrator must be connected only to a power supply which is in agreement with the VDE regulations.



To secure the motor from overload, it must be connected in series with a terminal circuit breaker, the normal current of which must be set to data, given on the machine plate.

The power connection

The power connection must be established only by means of a flexible cable. We recommend using the following cable type: NSSHÖU-J 4x 1,5², of 14 mm diameter, according to VDE 0250.

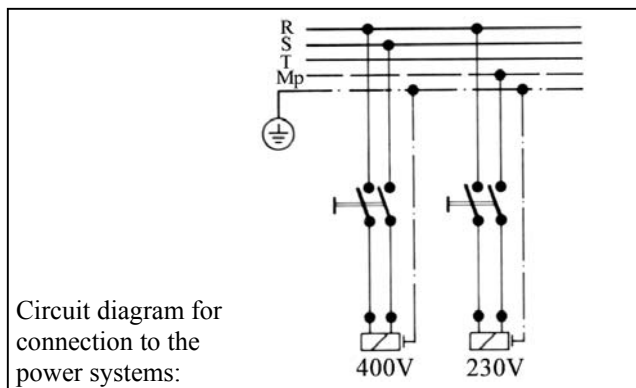
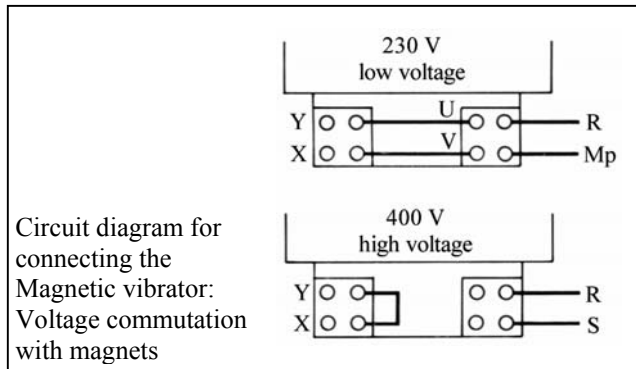

1. Remove approx. 80mm of the cable jacket.
2. Provide for wire case terminals on the two current carrying cables.
3. Shorten the protective cable end in such a way that there remain 30 mm of length after a 4 mm diameter cable eye has been attached.

Never fasten the terminals or sockets by soldering, as in default of this the strands tend to break behind the soldered spots in case of vibration
4. Remove the protective cover, introduce the cable through the screw joint and establish the connection as shown in the diagram.
5. When tightening the cap screw of the screw joint, it must be observed that the cable jacket is still fully seized by the seal. If this is not observed, the cable is not firmly clamped, not relieved from traction and not waterproof.
6. Close again carefully the protective cover with seal and screws.
7. The power cable must be fastened firmly shortly behind the cable gland. This first fastening of the cable and the motor should by no means be movable against each other. The cable has to be installed in such a way that it does not start vibrating itself and that it is not subject to any tractional forces.
8. When putting the vibration motor into operation the power input must be examined.

Now and again it must be checked that there are no spots which are subject to friction.

Putting into operation

With magnetic vibrators, the effect of vibration depends on the efficiency of the mass and the set clearance between magnet (item 10) and armature (item 3).

A stronger effect requires a smaller clearance and vice versa. The clearance will be changed after removing the protective cover by means of insertable brass spacer sheets (item 14 and 15). After loosening the two nuts (item 7), the clearance can be changed by removing or inserting spacer sheets between rubber buffer (item 13) and armature (item 3). The change must be equal on both sides.

Spacer sheets, which are required for this purpose, are stored between the ballast discs (item 11).

For low voltage the clearance ist set to 1.4 mm
For high voltage the clearance ist set to 1.2 mm



Noise caused by improper settings:
If the clearance is too small, the armature will beat against the magnet and with this cause a loud rattling noise.
Such noise must be suppressed by enlarging the clearance.

Maintenance

There is no need for maintenance since there are no parts that are subject to wear!



Spares

When placing orders for spares, please refer to the list of spares.

We point out to the fact that spares, which are not delivered by WÜRGES have not been tested by WÜRGES. Using spares from other manufacturers can impair predetermined qualities which are inherent in the construction and thereby influence negatively the active

or passive safety. WÜRGES reject any claim whatsoever, resulting from the use of spares from other manufacturers.

Please keep in mind that many cases, own specifications exist for components of WÜRGES and other manufacturers and that WÜRGES deliver always spares according to the latest art.

When placing orders for spares, never forget to mention the required number of pieces, the type or number; for fig. no. 10 also voltage and periodicity.

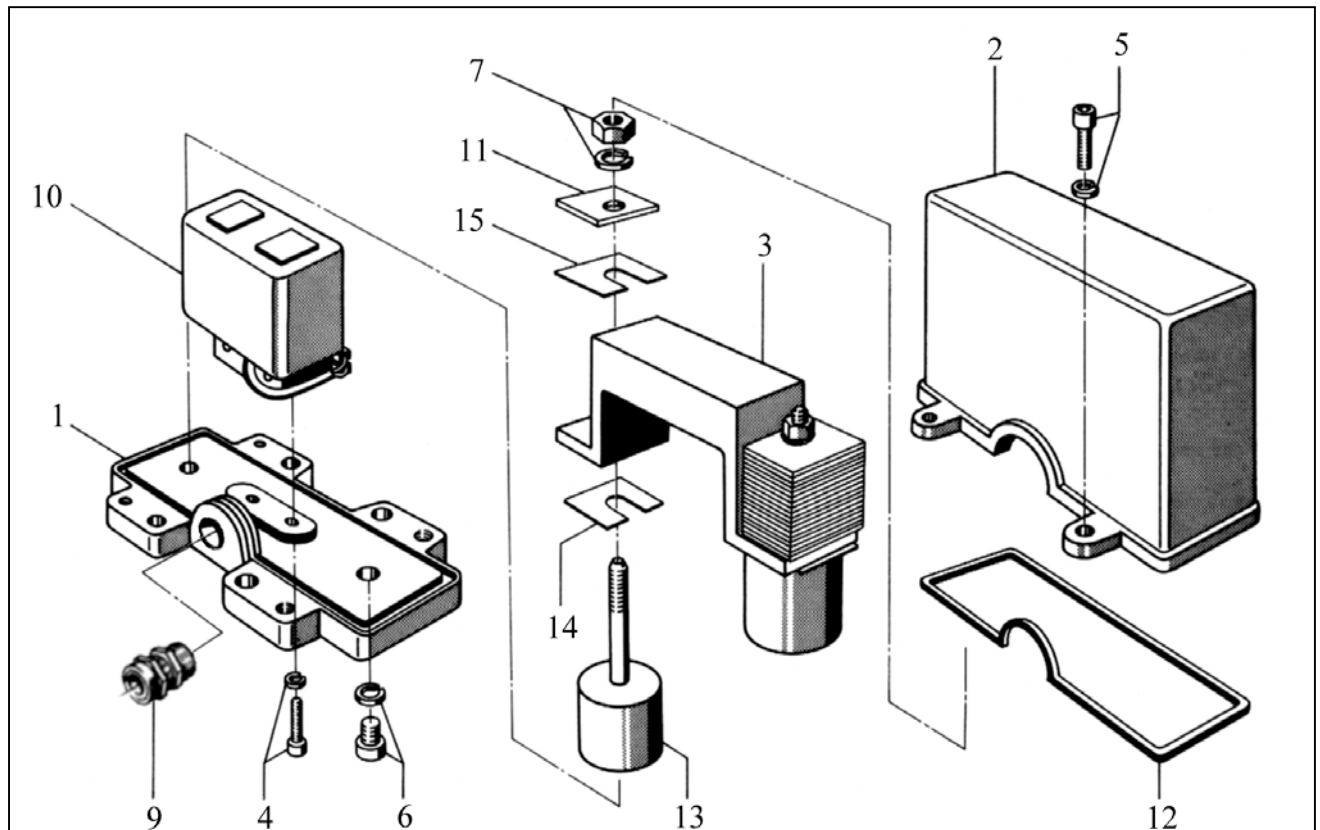

Fig. No.	Order No.	Pieces
1	05501	1
2	05601	1
3	05701	1
4	21601	2
5	22301	4
6	22501	2
7	28201	2
9	29491	1

Fig. No.	Order No.	Pieces
9	29701	1
10	62101	1
10	62201	1
11	75351	32
12	75831	1
13	76201	2
14	76501	0,5mm ~ 8
15	76511	0,2 mm ~ 8

MR-1
GMR-1

WÜRGES · Vibrationstechnik GmbH
D-86356 Neusäß/Augsburg
Daimlerstraße 9

telephone: 0049/(0)821/463081
telefax: 0049/(0)821/463084
e-Mail: info@wuerges.de
Internet: http://www.wuerges.de

