

**HV 0,8/2**

**List of spares**

When placing orders for spares, never forget to mention the required number of pieces, the type or

number; for illustration no. 15 also the voltage and periodicity.

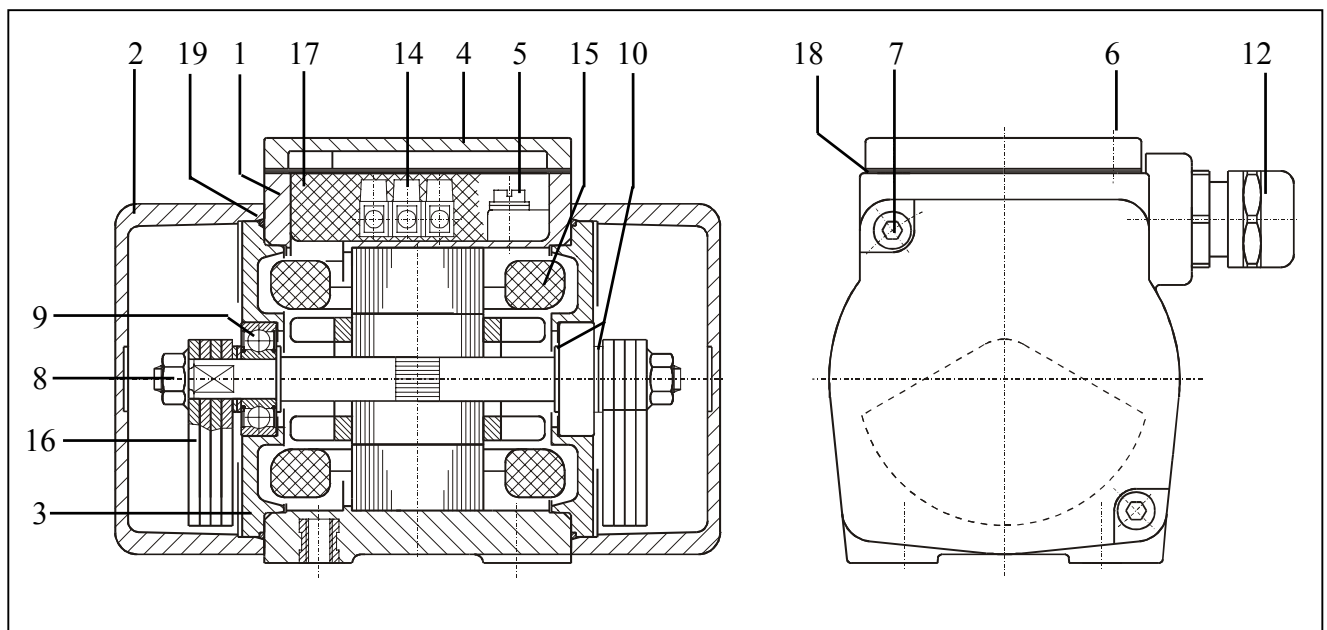

No.	Nomenclature	Order No.	Pieces
1	Gehäuse	00041	1
2	Schutzhaube	00301	2
3	Lagerschild	00081	2
4	Klemmkastendeckel	00401	1
5	Schraube M4x8 DIN 84	21101	1
6	Schraube M5x10 DIN 6900	21301	4
7	Schraube M5x45 DIN 912	21701	4
8	Flanschmutter M6	23801	2
9	Ri-Ku-Lager 629 ZZ C3	24001	2

No.	Nomenclature	Order No.	Pieces
10	Scheibe 9x15x1	26901	6
12	Kabelverschraub. M20x1,5	29491	1
13	Anker 0,4	45011	1
14	Klemmleiste	50751	1
15	Stator 400 V , 50 Hz	56401	1
16	Unwucht	75301	8
17	OWA-Band	75771	1
18	Klemmkastendichtung	75801	1
19	O-Ring 55x1,5	75901	2

**Particulars of winding**

	HV 0,8/2
∅ varnished wire	0,132
windings / groove	950
rated voltage	230/400 V - 50 Hz
insulant class	F
connection	series

WÜRGES · Vibrationstechnik GmbH  
 Daimlerstraße 9  
 D-86356 Neusäß/Augsburg  
 telefon: 0049/821/463081  
 telefax: 0049/821/463084  
 e-Mail: info@wuerges.de  
 Internet: http://www.wuerges.de

