

**HV 85/4-300**  
**HV 85/6-400**  
**HV 85/8-400**

## List of spares

When placing orders for spares, never forget to mention the required number of pieces, the type or

number; for illustration no. 1 also the voltage and periodicity.

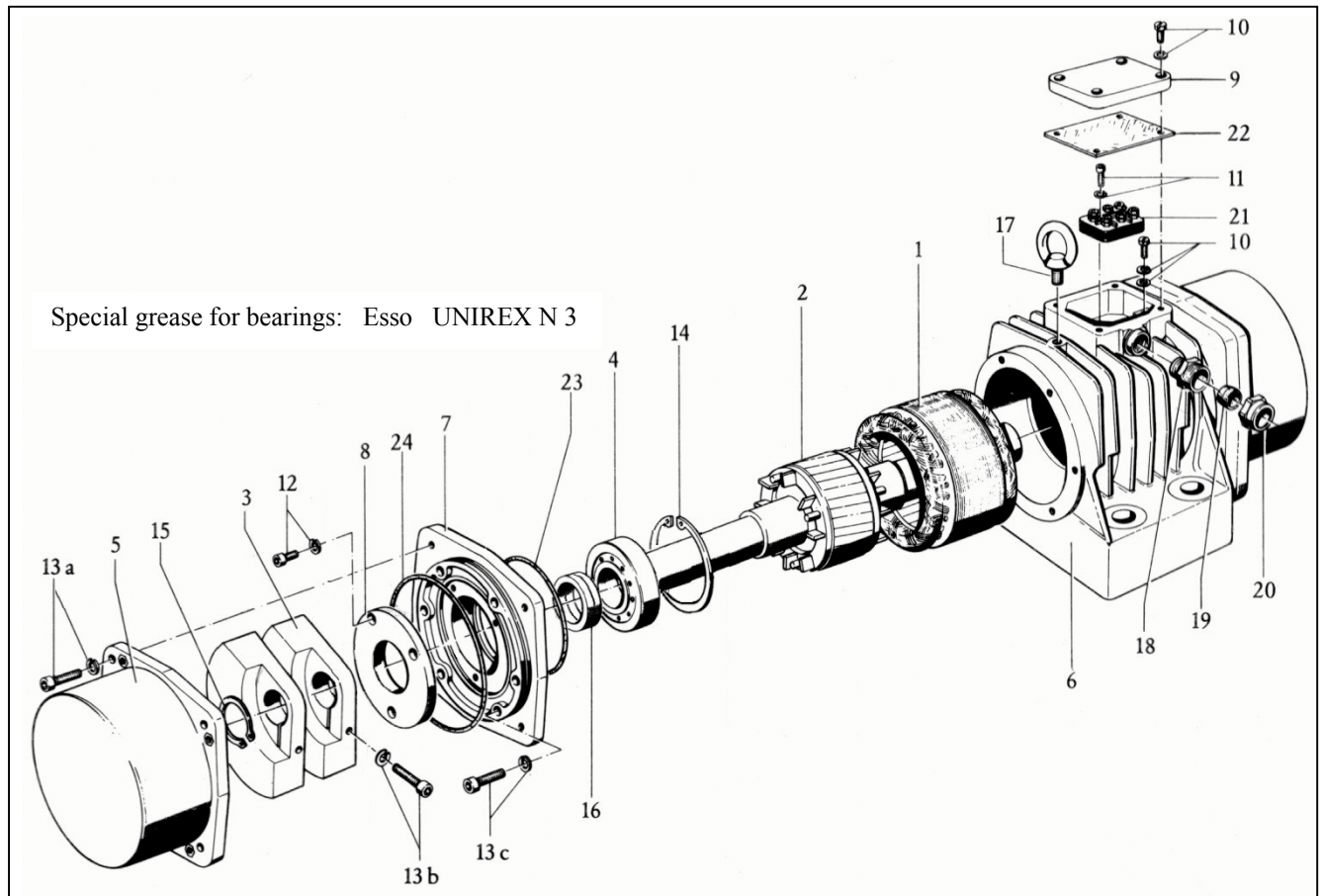

Fig. No.	Order No.	Pieces	
HV 85/4-300	1	59201	1
	2	48231	1
	3	75571	4
	4	25111	2
HV 85/6-400	1	59301	1
	2	48301	1
	3	75581	4
	4	24551	2
HV 85/8-400	1	59301	1
	2	48301	1
	3	75581	4
	4	24551	2

Fig. No.	Order No.	Pieces
5	05301	2
6	04901	1
7	05111	2
8	04501	2
9	05401	1
10	21401	5
11	21411	2
12	22501	6
13 a,b,c	23301	24
14	26401	2
15	26701	2
16	27601	4

Fig. No.	Order No.	Pieces
17	28101	1
18	29501	1
19	29601	1
20	29701	1
21	50901	1
22	75821	1
23	75691	2
24	75971	2



## Regulation of centrifugal force

For setting of the centrifugal force both the covers (part 5) must be removed. Thereafter the centrifugal force can be set infinitely variably if required. This is achieved by swivelling the extreme unbalanced disc A on the armature shaft. Make sure that the unbalanced discs are equally set on both sides of the vibrator.

The maximum centrifugal force is obtained when the extreme unbalanced disc (A) coincides with the interior one (B).

After setting is done both the covers must be mounted again. The centrifugal force can be set easily according to the tabel and the drawing below.

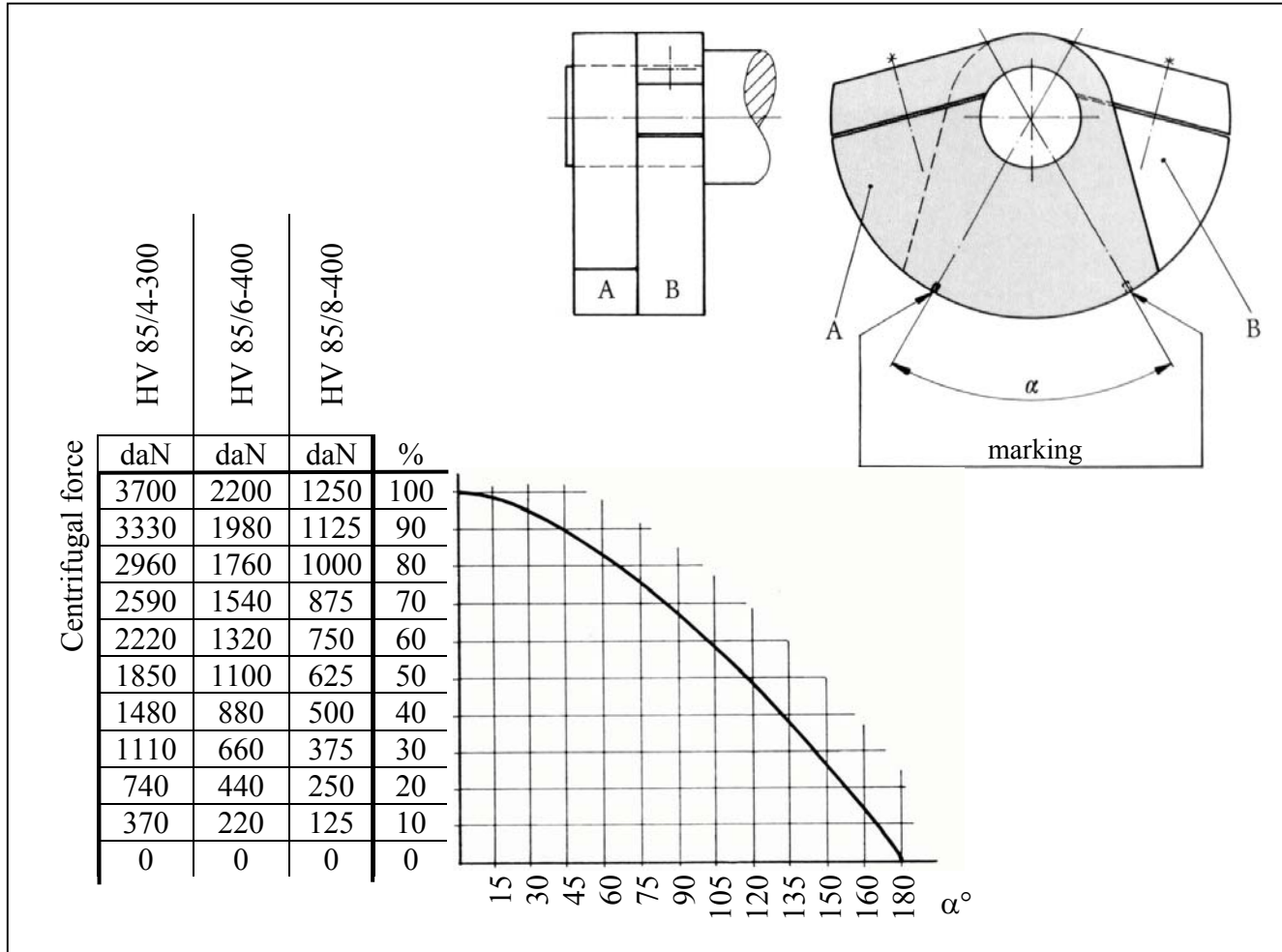

## Particulars of winding

type	HV 85/4	HV 85/6	HV 85/8
∅ varnished wire	3x0,6	0,67 + 0,71	0,75
windings / groove	50	65	47 + 47
rated voltage	230/400 V - 50 Hz	230/400 V - 50 Hz	230/400 V - 50 Hz
insulant class	F	F	F
connection	series	series	series

WÜRGES · Vibrationstechnik GmbH  
 D-86356 Neusäß/Augsburg  
 Daimlerstraße 9  
 telefon: 0049/821/463081  
 telefax: 0049/821/463084  
 e-Mail: info@wuerges.de  
 internet: http://www.wuerges.de

